

TOWER TANK SYSTEMS



TTS Cooling Tower Pump Tank Systems

ICE TTS Cooling Tower Pump Tank Systems deliver superior performance to your central chilled water system. A TTS System provides central pumping needs and control of cooling tower water in a pre-engineered package matched by Budzar Engineers to your process operation demands.

TTS units are capable of handling chiller capacities from 20 to 250 nominal tons.

Budzar also designs and manufactures specialized equipment for non-standard applications. Our engineers have extensive experience in process chilling and heating applications for such industries as: rubber, paper, plastics, chemical, food, and metal working. We take the time to understand your current and future needs and design a solution targeted at high quality and fast payback.



Bulletin #42

engineering
PRECISION

EXCELLENT RETURN ON INVESTMENT

- Each Budzar unit is designed to maximize the productivity of your process. Budzar quality and reliability provide excellent value for each dollar invested.
- Optional stand-by pumps eliminate down time and keep your process running.

LOW-COST, SIMPLE OPERATION AND MAINTENANCE

- Console-mounted high temperature, low pressure audible and visual alarms for process fluid supply allow you to attain peak process performance at all times.
- Close-coupled, centrifugal pumps with mechanical seals are selected for non-overloading conditions. Long-coupled, base-mounted pumps are optional.
- All pumps include lug-type isolation valves that remain stationary to permit complete pump removal without the inconvenience of water or fluid spillage.
- Multiple-stage thermostat monitors process water temperature and controls tower fan and pump to prevent tower cell icing during winter months.

QUICK AND EASY INSTALLATION

- Completely factory-assembled pump decks on as common skid
- All units are factory tested prior to shipment.



process
TEMPERATURE
control

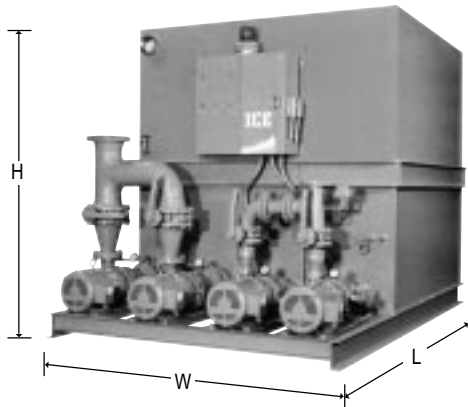

Model TTS-150D with individual stand-by pumps and manifolding. Unit has NEMA 1 electrical panel with high pressure/low temperature alarm system.

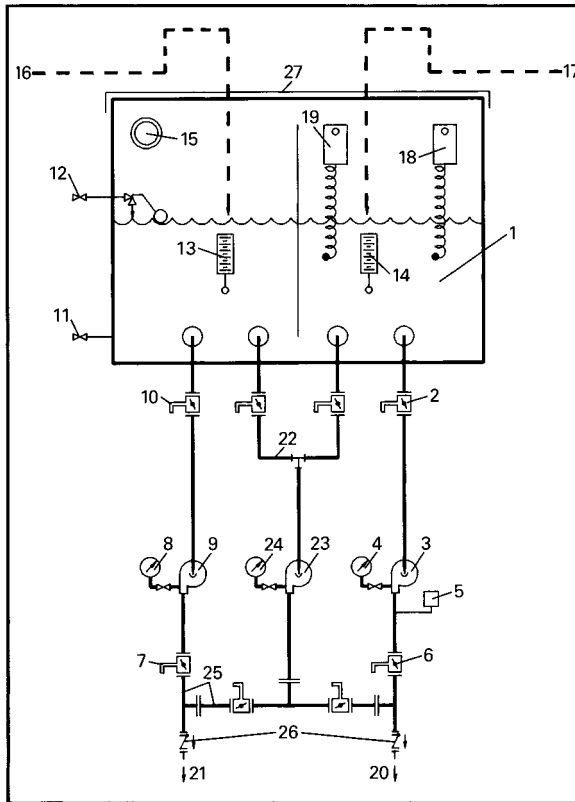

1. Insulated Reservoir and Baffle
2. Suction Shut-Off Valve
3. Process Pump
4. Process Water Pressure Gauge
5. Low Pressure Alarm Switch
6. Process Water Flow Control/ Shut-Off Valve
7. Tower Water Flow Control/ Shut-Off Valve
8. Tower Water Pressure Gauge
9. Tower Water Pump
10. Suction Shut-Off Valve
11. Drain Valve
12. Make-Up Water Float Valve with Shut-Off Valve
13. Process Return Thermometer
14. Tower Return Thermometer
15. Overflow Port
16. Return from Process
17. Return from Tower
18. High Temperature Alarm Thermostat
19. Tower Fan and Tower Pump Cycling Thermostat (Two Stages)
20. Process Water Supply
21. Tower Water Supply

Options As Shown

22. Standby Pump Suction Manifold
23. Standby Pump
24. Standby Pump Pressure Gauge
25. Standby Pump Discharge Manifold
26. Discharge Check Valve
27. Reservoir Cover

TTS DUAL PUMP COOLING TOWER TANK SYSTEMS

MODEL TTS		TTS-020D	TTS-040D	TTS-065D	TTS-100D	TTS-150D	TTS-200D	TTS-285D
Maximum Duty -	TONS	20	40	65	100	150	200	285
Tank Size L x W x H -	FEET	2.5 x 5 x 3	4 x 5 x 4	4 x 5 x 4	4 x 6 x 6	5 x 7 x 6	5 x 7 x 6	6.5 x 7.5 x 7
Tank Capacity - Overflow -	GALLONS	220	500	500	950	1,400	1,400	2,250
Operating -	GALLONS	140	300	300	600	900	900	1,400
Tower Pump - Flow @ PSIG	GPM / PSI	60 / 23	120 / 27	195 / 26	300 / 27	450 / 22	600 / 26	855 / 26
Pump Motor -	HP	1.5	3.0	5.0	7.5	10	15	20
Discharge Connection -	INCHES	2 NPT	2 1/2 FLG	4 FLG	4 FLG	6 FLG	6 FLG	8 FLG
Process Pump - Flow @ 60 PSIG -	GPM	60	120	195	300	450	600	855
Pump Motor -	HP	5.0	7.5	10	15	25	30	40
Discharge Connection -	INCHES	2 NPT	2 1/2 FLG	4 FLG	4 FLG	6 FLG	6 FLG	8 FLG
Nameplate Amps @ 460 / 3 / 60 -		10.2	15.8	21.6	32	48	61	79
230 / 3 / 60 -		20.4	31.6	43.2	64	96	122	158
Connections (NPT) Overflow -	INCHES	2	3	3	4	4	4	4
Makeup -	INCHES	1/2	1/2	1/2	3/4	3/4	3/4	3/4
Drain -	INCHES	1 1/2	1 1/2	1 1/2	2	2	2	2
Shipping Weight (Approx.) -	LBS	950	1,700	1,750	2,000	4,200	4,300	7,100
Operating Weight (Approx.) -	LBS	2,800	5,850	5,900	10,000	15,900	16,000	25,500
Dimensions (Approx.) WxLxH -	INCHES	63x75x60	63x92x74	63x99x81	75x101x81	87x121x81	87x121x81	93x141x93

NOTE: Standby pumps are available for all models, (mounted, piped and wired) as a recommended option. Standby pump is identical to process pump.

TTS SINGLE PUMP COOLING TOWER TANK SYSTEMS

(Recommended when process temperature control is not critical)

MODEL TTS		TTS-020S	TTS-040S	TTS-065S	TTS-100S	TTS-150S	TTS-200S	TTS-285S
Process / Tower - Flow @ 60 PSIG -	GPM	60	120	195	300	450	600	855
Pump Motor -	HP	5.0	7.5	10	15	25	30	40
Nameplate Amps @ 460 / 3 / 60		7.6	11	14	21	34	40	52
230 / 3 / 60		15.2	22	28	42	68	80	104

NOTE: Standby pumps are available for all models, (mounted, piped and wired) as a recommended option. Standby pump is identical to process pump.

Budzar Industries reserves the right to discontinue or change specifications without notice, consistent with sound engineering practice and current industrial standards.



38241 Willoughby Pkwy., Willoughby, Ohio 44094-7582
 (440) 918-0505 • Fax (440) 918-0606/918-0707
 Internet: www.budzar.com
 E-mail: sales@budzar.com